

Canonical Correlation Analysis on Life Stress and Learning Burnout of College Students in Taiwan

Huang, Yun-Chen¹; Lin, Shu Hui^{2*}

Author¹ is affiliated with department of Accounting information, National Taichung Institute of Technology, Taiwan
Author² is affiliated with department of Insurance and Finance, National Taichung Institute of Technology, Taiwan
Contact author: S. H. Lin^{2*}; 129 Sec.3, Sanmin Road, Taichung City 404, Taiwan, R.O.C. **Phone:** 0422196108;
Email: suelin@ntit.edu.tw

Submitted: September 21, 2010; Revised and Accepted December 28, 2010.

Abstract

With rapid social changes, stress in life has increased significantly for everyone including college students. Understanding life stress among college students and how it may affect learning burnout has become an important concern for education researchers. The purposes of this study were (1) to assess the current status and factor structures of college students' learning burnout, and (2) to explore the relationship between life stress and learning burnout. The participants included 3,247 convenient samples of college students in Taiwan. The Learning Burnout Scale and The Life Stress Scale were used as assessment instruments for the study. Results of data analysis found that the students' learning burnout could be described by four factors: "low sense of achievement", "interpersonal alienation", "negative learning emotion", and "emotional exhaustion". Among these factors, "low sense of achievement" and "negative learning emotion" were found to be more serious. Using canonical correlation analysis the study also found a significant correlation between life stress and learning burnout. Results suggested that the higher the life stress the student experiences, the higher the degree of their learning burnout.

Keywords: canonical analysis, college students, learning burnout, life stress

Introduction

With rapid changes in social, political, and economic life of global society, students in school often face many life stresses, such as academic pressure, emotional distress, role ambiguity, career and achievement stress, stress from family expectations, value conflict, emotional instability, and feelings of alienation. Excessive stress can impose a negative impact on students' learning, even placing students at risk of learning burnout.¹

Previous studies of burnout focused primarily on professionals who help others. These studies found that the long-term stress of work and over-stimulation of individual, mental, physical, and other resources, caused depletion of energy and physical or mental exhaustion. It often led individuals to feel helpless and to display symptoms of emotional exhaustion.²⁻³ Maslach & Schaufeli⁴ referred to this phenomenon as "the three-factor model of career burnout". Until now the theory has been a major reference for researchers who study career burnout. According to the theory, career burnout has three primary aspects: (1) low sense of achievement – a negative reaction of sense of achievement regarding the individual and the individual's work. The individual feels depressed, withdrawn, ineffective, and generally unresponsive; (2) depersonalization – a negative emotion associated with personal interactions, the individual loses his or her original enthusiasm or attitude, acts or reacts inappropriately toward his or her clients and colleagues; (3) emotional exhaustion – a mental and physical sense of powerlessness, the individual feels physical exhaustion, energy depletion, emotional exhaustion, loss of pleasure, lethargy. Many of these studies targeted professionals whose work requires them to have a close interaction with others such as doctors, nurses, social workers, teachers, and police officers. These professionals not only must possess and provide professional knowledge or skills to others, but also must have frequent interactions with groups of people. When the working conditions are less than ideal and potential problems occur (e.g., personality, personal life, etc.), these professionals may gradually lose their idealism, energy and goals. After a period of time, they may eventually suffer from career burnout.

The general version of the Maslach Burnout Survey (Maslach Burnout Inventory- General Survey, MBI-GS)⁵ has been applied to many areas when studying burnout. Researchers who are concerned with students' psychological development have gradually

extended the career burnout theory to academic learning areas.⁶⁻¹¹ These studies found that burnout also appears in students' population. In the view of Meier & Schmeck¹² and McCarthy, Pretty & Catano,¹³ learning burnout is one of the common experiences of college students. According to researches,¹⁴⁻¹⁵ students who suffer from learning burnout often display the following characteristics: (1) Decreased learning and learning motivation. (2) Negative changes in their affective and cognitive function, significant loss learning enthusiasm and energy. (3) Inability to properly cope with stress and frustration with homework; appearing not to care about schoolwork. (4). Appear to have depleted physical resources. (5). Negative learning experiences from excessive high expectations, thus losing their sense of accomplishment. (6). Display alienation or withdrawal behaviors toward school tasks and activities, such as being late for school, leaving early, being absent or dropping out.

Learning burnout is an expansion of the idea of career burnout. Some researchers pointed out,^{6, 14, 15} the symptoms include the emotional exhaustion, depersonalization, and appearance of low personal accomplishment. From our teaching experience in Taiwan, we found that college students in Taiwan may show negative learning emotion in addition to the symptoms mentioned above.

The cause of individual feeling burnout is related to a number of factors, but stress factors are the most widely discussed. As Weiten¹⁶ stated for the theory of career burnout, once individuals in a working environment suffer stress, it may produce emotional exhaustion and probably cause a negative emotion associated with personal interactions, thereby affecting the performance of work, so they fail to achieve a sense of accomplishment, the so-called phenomenon of burnout. Additional research findings¹⁷ also supported this argument that there is a close connection between stress and burnout. The same study also indicated that the higher the work stress, the more serious the career burnout. Although college students have not yet entered the job market and they do not face work-related stress, but for college students in Taiwan, "academic learning" has been their primary source of stress beginning from kindergarten to university. Several researches on college students' stress in Taiwan suggested that students are not just experiencing academic stress, but also face a variety of life stress, and this stress is increasing every year.¹⁸⁻²⁰ This will inevitably have an impact on students' learning when life is stressed.

Archer & Lamnin¹ suggested that excessive stress on students will have a negative impact on learning.

Although previous studies have investigated students' schoolwork performance, most of them focused on learning motivation, learning anxiety, learning satisfaction and other issues, and few have explored learning burnout. As the society continues to evolve and change and increasing pressure for achieving success in higher education, it is important for educators to examine students' learning, especially learning burnout. Study of student's burnout may help to understand students' learning performance and to develop strategies for prevention.

Purpose of Study

This study was designed to assess students' learning burnout which includes exploring the components and dimensions of learning burnout behaviors and analyzing the overall learning burnout problem. In addition, canonical correlation analysis was used to investigate the relationship between life stresses and learning burnout factors.

Method

Participants and Procedure

Participants were recruited by convenience sampling. First, nine universities were randomly selected from the north, central and south regions of Taiwan. Second, 8-10 classes were randomly selected from each university. The questionnaires were administered in classes during the period between 2008 and 2009 with a total of 3,812 students in all selected classes. A consent letter was attached on the top of the questionnaire to ensure voluntary and anonymous participation. The students were informed that all the data would remain confidential, and would only be reported by group. The students were permitted to leave at anytime during the survey. A total of 3,247 valid surveys were collected excluding surveys with incomplete data. The effective response rate was 85.12%. Among all respondents, 46.1% were males, 53.9% females. About 25.9% of the respondents were freshmen, 25.3% sophomores, 26.5% juniors, and 22.3% seniors. The valid questionnaires were analyzed using the SPSS and LISREL software package for statistical analysis.

Instruments

The survey used in this research included three parts; the first part was basic information about schools, grades and genders, the second and the third parts were revised versions of "The Learning Burnout Scale" and "The Life Stress Scale". The "Learning Burnout Scale" was based upon the Maslach Burnout Inventory,²¹ with some items revised according to Taiwan's educational environment to make it suitable for Taiwan students. The "College Life Stress Scale" was revised research instrument proposed by Lu.²² These two scales are described below.

The Learning Burnout Scale

The original instrument has shown construct validity and reliability in previous research.²³⁻²⁶ For example, Bilge took 194 college teachers as study participants and showed the Maslach Burnout Inventory has 3 subscales with Cronbach's α coefficients .830, .650 and .720. The revised scale in this study was constructed by carrying out a pre-test on 85 college students to assess construct validity of the items and conducting a factor analysis to remove the items with factor loading less than 0.5.

Finally, there were total of 19 questions in the formal scale, using a Likert five-point scale, with ratings from "always", "often", "sometimes", "seldom" to "never", assigned 5, 4, 3, 2 and 1 points respectively, so that the higher the score, the stronger the degree of learning burnout. For the valid samples in this research, the scale KMO value was .873, the value of the spherical chi-square was $\chi^2=10,959.126$ with p value = .00 which is statistically significant at a nominal .05 level. This result indicated the data collected are suitable for factor analysis, adopting principal component for factor extraction, using Promax for oblique factors, and remove items with factor loading of less than 0.5. Based on the results four items were deleted and four factors were extracted from the 15 questions, named as "low sense of achievement", "interpersonal alienation", "negative learning emotion", and "emotional exhaustion" respectively. These four factors explained 58.1% of the total variance. Each dimension and the total scale of Cronbach's α coefficients was .613, .719, .704, .780 and .843, respectively. As can be seen, the revised "College Students Learning Burnout Scale" has good reliability and validity.

In order to test the "Learning Burnout Scale" of the MBI¹⁸ for applicability of Taiwan students, the LISREL statistical software was used for validation

of the four-factor model of this scale. In terms of the overall goodness of fit, the GFI, AGFI, NNFI, CFI values were greater than .90, PNFI, PGFI values were also greater than .50, RMSEA value was smaller than .6. These showed the overall model fit well. In terms of the internal structure of goodness of fit, the individual observed variables reliability were greater than .50, the component of the latent variables reliability was greater than .60, and the average variation extraction of the latent variable were all more than .50, showing that this model also fit well for internal structure. Therefore, Taiwan students' learning burnout behavior can be accurately evaluated by these four aspects: low sense of achievement, interpersonal alienation, negative learning emotion, and emotional exhaustion.

The Life Stress Scale

The original scale has 6 subscales with Cronbach's α coefficients between .690 and .920.²² Construct validity and reliability have been shown in previous research, and has been used to assess college populations.²⁷⁻²⁸ The scale was adapted after a sequence of steps similar to the scale described above to establish its validity and reliability in the study. The final instrument consisted of 29 items, using a Likert four-point rating scale, with ratings classified as "no impact", "slight impact", "often affect," "great impact" assigned 1, 2, 3, and 4 points respectively. The assessment indicated that the higher the score, the larger the perceived impact from stress life events. Participants' responded in their own practical experience over the past year, on the common stressful events scale, according to their degree of distress. For the valid samples, the scale KMO value was .872, the value of the spherical chi-square was $\chi^2=21507.888$ with p value = .00, indicating the data are suitable for factor analysis, using the same procedure described above. Based on the results, three items were deleted and six factors were extracted from the remaining 26 items, named as "academic stress", "interpersonal stress", "family stress", "emotional stress", "future development stress", and "self-identity stress" respectively. The cumulative variance of these six factors was 56.6%, the Cronbach's α coefficients for each dimension were .671, .732, .786, .782, .802, .701 and .858, respectively. It is clear that, "The Life Stress Scale" also has acceptable reliability and validity.

Likewise, we applied the LISREL statistical software for validation of this scale. Results showed the indices of preliminary fit criteria, overall model fit,

and internal structure fit were all up to the criterion. Therefore, respondents' life stress can be accurately assessed by these six aspects: academic stress, interpersonal stress, family stress, emotional stress, future development stress, and self-identity stress.

Results

Table 1 shows the means and standard deviations of Taiwan students' learning burnout and life stresses. The means of each item of all participants' life stress were about 2.00 on average, indicating that the life stress was close to the level of "slight impact". Among them, the degree of "future development stress" was the highest, and the next ones were "academic stress" and "self-identity stress". Meanwhile, the means of learning burnout are all between 2.00 and 3.00 points, i.e., between "seldom the case" and "happen sometimes", for the two factors of "low sense of achievement" and "negative learning emotion".

Table 2 shows the summary of the canonical correlation analysis. Results showed significant relationships between the linear combination of all variables of learning burnout and the linear combination of all variables of life stress. These two sets of variables were significantly related and the correlation coefficients were .512 and .345. The first and the second canonical correlation structures of life stress and learning burnout are explained below.

The first canonical correlation structure of life stress and learning burnout

The related structure of the first canonical correlation is illustrated in Figure 1. The main points of the canonical correlation emphasize the connection of combinations from factors and the symbols of "+" and "-" show the directional relationship. In the first canonical correlation structure, we can tell that students with higher scores related to the stress of life events, scored higher on the factors related to learning burnout; that is, the higher the degree of stressful life events experienced by students, the more serious the learning burnout symptoms in all aspects.

The second canonical correlation structure of life stress and learning burnout

Figure 2 is the related structure of the second canonical correlation. From Figure 2, it shows a weaker relationship than the first one. In this structure, in view of the factor loading, students who scored lower in "family stress", "interpersonal stress", and "emotional stress", and scored higher in "future development stress", had a lower score in "interpersonal alienation" and "emotional exhaustion" for learning burnout, but scored higher in "low sense of achievement" and "negative learning emotion". This result indicated that students with lower degree of stress due to a variety of family, social and emotional events, and the higher level of future development stress showed less interpersonal alienation and energy depletion, but it would lead to "low sense of achievement" and "negative learning emotion".

Discussion

Unlike studies of students in other countries (such as the United States, Spain, Portugal, the Netherlands, etc.) which all used a three-factor model theory to explore students' learning burnout behaviors,^{6-8,10} this research identified an additional factor, "negative learning emotion", in the learning burnout behaviors of Taiwanese students. Although this factor is similar to "emotional exhaustion" in emphasizing negative development of emotions, the latter tends to be a more general psychological factor in which the student appears to have a lack of energy and depletion of body resources; the "negative learning emotion" factor tends to be a more specifically academic factor, meaning that the student feels tired, bored, lacks enthusiasm for, and generally rejects school works and seeks escape. Therefore, we regard 'emotional exhaustion' and 'negative learning emotion' as two different factors in studying burnout of Taiwanese students. However, it needs further research to see whether the four-factor model is only applied to students in Taiwan.

In the literature, there are plenty of researches focused on the relationship between workers' job burnout and stress. Most of researches^{17, 30-32} carried out investigation by considering the entirety of burnout and stress instead of discussing specifically the relationship of their factors. These studies revealed that the results of the job burnout had a significantly positive relationship with workers' job stress. Tai and Lee³³ applied canonical correlation analysis in their study and further found that there exist canonical correlation between respondents' job stress and burnout. In the study, the researchers

revealed that linear combination of job stress (work load, work support, social interaction, and professional knowledge) might impact the linear combination of job burnout (emotional exhaustion, depersonalization, and low sense of achievement) for sports administrators. In the present study, using canonical correlation analysis in students also revealed similar relationship as professionals between stress and burnout.

In addition to helping professionals, many studies of students in other countries, also found that there is a close relationship between students' life stress and learning burnout. For example, Dyrbye, et al.²⁹ found that the learning burnout for medical students are not just related to work stress but also have close connections with the individual's life events, especially negative life events. This study using Taiwan students as participants also supported that there is indeed a close relationship between students' life stress and their learning burnout.

Finally, the results from the second set of canonical correlation showed that even when the family, interpersonal, and emotional distress were low, as long as the stress related to future development was high, students still displayed a high degree of burnout symptoms reflected especially in their sense of achievement and learning. While the degree of interpersonal alienation and emotional exhaustion were low, the depressed emotion about low sense of achievement and negative feeling of learning were high. This phenomenon might occur in our diverse and changing society. Students in Taiwan appear to embrace the concept of "you can find success in any job or profession" and success in academic is not the only choice for future. This probably contributes to the tendency of students in Taiwan to turn negative toward learning or even to escape from it. This result is worthy of the attention and concern of education officials.

Conclusion

This study intended to examine the components and situation of learning burnout of college students in Taiwan. By applying the factor analysis and the canonical correlation analysis, we found that there contained 4 factors in Taiwanese college students' learning burnout and there was a significant relationship between students' life stress and learning burnout. The higher their stress in life, the higher their learning burnout will be.

Based on the findings, we recommend that education officials in Taiwan or professionals who are interested in college students' learning should pay attention to students' stress coping abilities. As we know, most of universities have established organizations to provide students counseling. School administrators may encourage students to make good use of them. In addition to common courses, universities may consider offering courses such as emotional management, relaxation training, stress management and assertion training, or integration of stress management training into students' general education courses. By teaching students how to face life stresses and how to better cope with the stresses, it should be quite helpful toward reducing the degree of students' learning burnout.

Acknowledgments

We are grateful to the editor and anonymous reviewers for their helpful comments and suggestions which improved the final version of the paper.

References

1. Archer, P. J. & Lamnin, A. An investigation of personal and academic stressors on college campuses. *Journal of College Student Personal.* 1986; 26(3): 210-215.
2. Burke, R. J., & Greenglass, E. R. Effects of changing hospital units during organizational restructuring. *Health Care Manager.* 2007; 20, 10-18.
3. Maslach, C., Schaufeli, W. B., & Leiter, M. P. Job burnout. *Annual Review of Psychology.* 2001; 52: 397-422.
4. Maslach, C., & Schaufeli, W. B. *Burnout: The cost of caring.* Englewood Cliffs: Prentice-Hall. 1982.
5. Schaufeli, W. B., Leiter, M. P., Maslach, C., & Jackson, S. E. *Maslach Burnout Inventory-General Survey.* In C. Maslach, S. E. Jackson, & M. P. Leiter (Eds.), *The Maslach Burnout Inventory-Test Manual* (3rd edn.). Palo Alto, CA: Consulting Psychologists Press. 1996.
6. Balogun, J. A., Helgemoe, S., Pellegrini, E., & Hoerberlein, T. Academic Performance is not a viable determinant of physical therapy students' burnout. *Perceptual and Motor Skills.* 1996; 83: 21-22.
7. Chang, E. C., Rand, K. L., & Strunk, D. P. Optimism and risk for burnout among working college students: Stress as a mediator. *Personality and Individual Differences.* 2000; 29: 255-263.
8. Law, D. W. A measure of burnout for business burnout. *The Journal of Education for Business.* 2010; 85(4): 195-202.
9. Jacobs, S. R., & Dodd, D. K. Student burnout as a function of personality, social support, and workload. *Journal of College Student Development.* 2003; 44(3): 291-303.
10. Schaufeli, W. B., Martínez, I., Marqués-Pinto, A., Salanova, M. & Bakker, A. Burnout and engagement in university students: A cross-national study. *Journal of Cross-Cultural Psychology.* 2002; 33: 464-481.
11. Yang, H. J. Factors affecting student burnout and academic achievement in multiple enrollment programs in Taiwan's technical-vocational colleges. *International Journal of Educational Development.* 2004; 24(3): 283-301.
12. Meier, S. F. & Schmeck, R. R. The burned-out college student: A descriptive profile. *Journal of College Student Personnel.* 1985; 26(1): 63-69.
13. McCarthy, M. E., Pretty, G. M. & Catano, V. Psychological sense of community and student burnout. *Journal of College Student Development.* 1990; 31: 211-216.
14. Lingard, H. C., Yip, B., Rowlinson S. & Kvan, T. The experience of burnout among future construction professionals: A cross-national study. *Construction Management and Economics.* 2007; 25(4):345-357.
15. Zhang, Y., Gan, Y. & Cham, H. Perfectionism, academic burnout and engagement among Chinese college students: A structural equation modeling analysis. *Personality and*

- Individual Differences*. 2007; 43(6): 1529-1540.
16. Weiten, W. *Psychology – Themes and Variations*. Pacific Grove: Brook/Cole. 1998.
17. Brewer, E. W., & McMahan, J. Job stress and burnout among industrial and technical teacher educators. *Journal of Vocational Education Research*. 2003; 28(2): 125-140.
18. Lee, C. C. & Chen, C. Y. Pressure faced and coped by senior students of National Taiwan Normal University and related factors. *Chinese Journal of School Health*. 2004; 44: 1-31.
19. Shih, J. B. Correlates of the mental health of freshmen. *Journal of Da-Yeh University*. 2004; 13(2): 109-117.
20. Tsai, W. Y. A study of stress and coping strategies in Technology college student. Unpublished master's thesis, Tainan University of Technology, Taiwan. 2005.
21. Maslach, C., Jackson, S. E. & Leiter, M. P. *Maslach Burnout Inventory Manual*. Consulting Psychologists Press, Inc. Palo Alto, CA. 1996.
22. Lu, Y. L. A study on the life stress and stress coping strategy of the National Taichung Teachers College students. Unpublished master's thesis, National Taichung University. 2004.
23. Richardsen, A. M., & Martinussen, M. The Maslach Burnout Inventory: Factorial validity and consistency across occupational groups in Norway. *Journal of Occupational and Organizational Psychology*. 2004; 77(3): 377-384.
24. Bilge, F. Examining the burnout of academics in relation to job satisfaction and other factors. *Social Behavior & Personality: An International Journal*. 2006; 34(9), 1151-1160.
25. Demerouti, E., Bakker, A. B., Vardakou, I. & Kantas, A. The convergent validity of two burnout instruments: A multitrait-multimethod analysis. *European Journal of Psychological Assessment*. 2003; 19(1): 12-23.
26. Dyrbye, L. N., Thomas, M. R., Massie, F. S., Power, D. V., Eacker, A., Harper, W., Durning, S., Moutier, C., Szydlo, D. W., Novotny, P. J., Sloan, J. A. & Shanafelt, T. D. Burnout and suicidal ideation among U.S. medical students. *Annals of Internal Medicine*. 2008; 149(5): 334-341.
27. Huang, Y. C. & Lin, S. H. A study of the emotional intelligence and life stress of college students in central Taiwan. *Journal of National United University*. 2009; 6(2): 19-42.
28. Lin, S. H. & Huang, Y. C. College students' capacity to be alone with life stress and their personal variables – taking central Taiwan as an example. *Journal of Education National Changhua University of Education*. 2009; 16: 75-102.
29. Dyrbye, L. N., Thomas, M. R., Huntington, J. L., Lawson, K. L., Novotny, P. J., Sloan, J. A., & Shanafelt, T. D. Personal life events and medical student burnout: A multicenter study. *Academic Medicine*. 2006; 81(4): 374-384.
30. Li, W. C. & Chang, S. H. A Study of Employees Attending Leisure Sports on Job Stress and Burnout. *Journal of Leisure and Tourism Industry Research*. 2009; 4(2): 71-83.
31. Lu, L., Lee, H. M., & Shieh, T. Y. Occupational stress, health and occupational burnout among dentists: A study of clinical dentists in Kaohsiung. *Research in Applied Psychology*. 2005; 27: 59-80.
32. Huang, B. Y. Impact of Job Stress on Job Satisfaction and Burnout: A Meta-Analysis. *Bulletin of Educational Psychology*. 2009; 40(3): 439-461.
33. Tai, H. H. & Lee, H. F. A study on the relationship between job stress and working burnout for civil servants in physical education administrative organizations. *Journal of Sport and Recreation Research*. 2007; 2(1): 44-55.

Table 1. Means and the standard deviations of undergraduate life stresses and burnout

	Items	Mean	Standard deviation
Life stress	Academic stress	2.153	.571
	Family stress	1.586	.641
	Interpersonal stress	1.661	.671
	Emotion stress	1.579	.674
	Future development stress	2.372	.669
	Self-identity stress	2.100	.640
	Overall life stress	1.944	.414
Learning burnout	Low sense of achievement	2.809	.803
	Interpersonal alienation	2.287	.777
	Negative learning emotion	2.658	.820
	Emotional exhaustion	2.433	.816
	Overall learning burnout	2.531	.601

Table 2. The summary table of the canonical correlation analysis

X variable	Canonical variables		Y variables	Canonical variables	
	χ_1	χ_2		η_1	η_2
Academic stress	.546	-.006	Low sense of achievement	.753	.491
Family stress	.358	-.579	Interpersonal alienation	.659	-.532
Interpersonal stress	.587	-.714	Negative learning emotion	.677	.215
Emotional stress	.244	-.648	Emotional exhaustion	.847	-.320
Future development stress	.761	.384	the percentage of variation	54.377	16.813
Self-identity stress	.799	.033	Overlap (%)	14.262	2.004
the percentage of variation	34.120	23.554	ρ^2	.262	.119
Overlap (%)	8.949	2.808	Canonical correlation(ρ)	.512***	.345***

*** $p < .001$

Figure 1. The figure for the first canonical structure of life stress and learning burnout

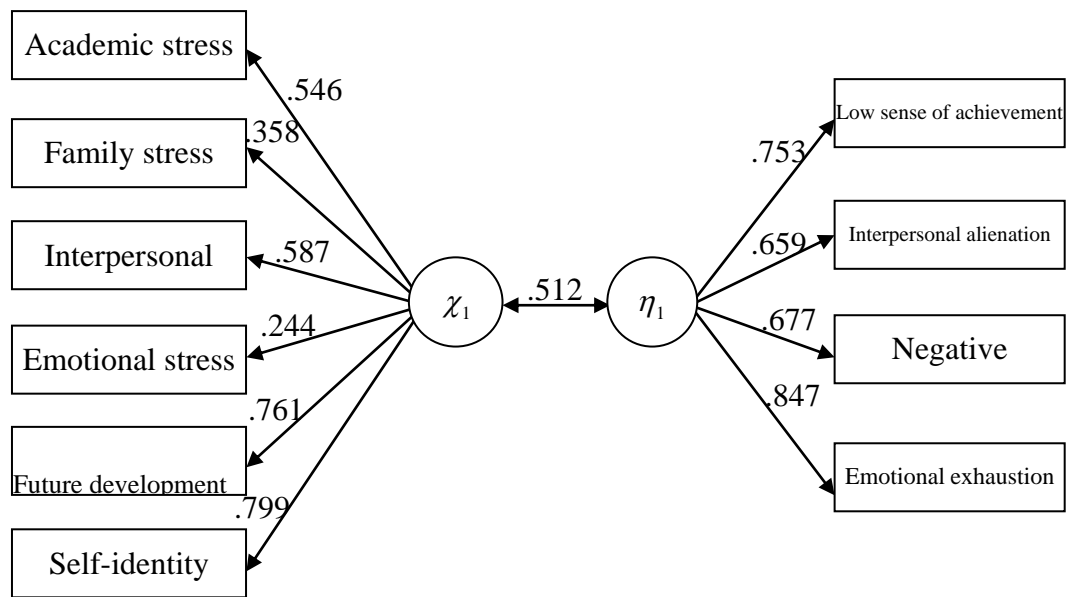

Note: This chart displays factors whose canonical correlation loading is greater than .20; “+”, “-” shows the directional relationship

Figure 2. The figure for the second canonical structure of life stress and learning burnout

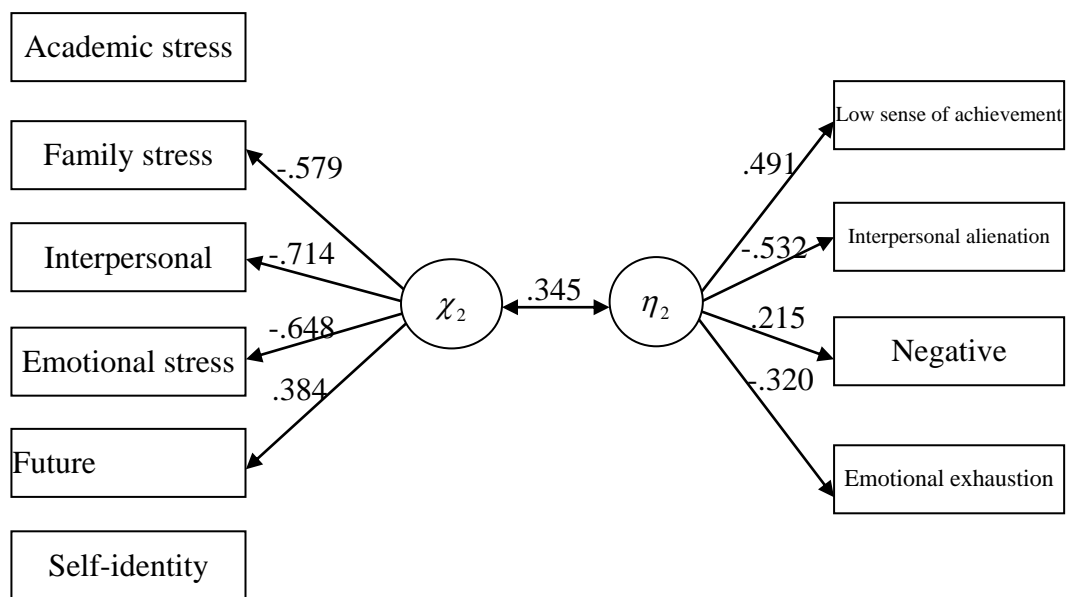

Note: This chart displays factors whose canonical correlation loading is greater than .20; “+”, “-” shows the directional relationship